

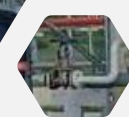

CADABCO LTD

gogreen



Loading Gantry VRU



INTRODUCTION

Philosophie and advantage

The aim of the GANVAC is to offer an alternative to the « classical » VRU system and to reduce the overall investment for the vapour recovery system.

The Ganvac is a machine who will be installed directly in the loading gantry and the recovered product will be transferred to the truck

The Advantage of the system compared to the “classical” VRU are

- No need of vapor header
- No connection to storage tank
- No need of a specific concrete foundation
- No remote control cabinet
- Detonation arrester and vapor arm included in the unit
- Request only power supply and instrument air
- Each gantry will be independent
- No expensive equipment's like big vacuum pumps
- Easy maintenance
- Reduce overall cost
- Plug and play system

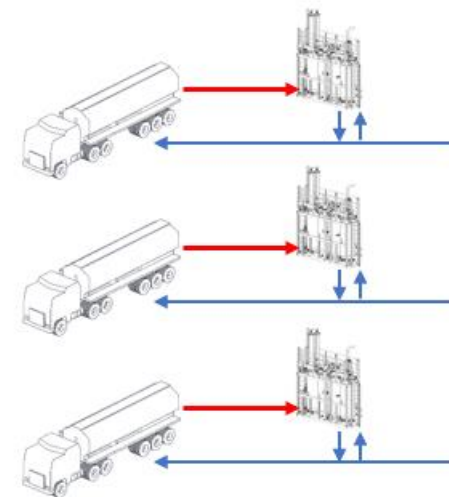
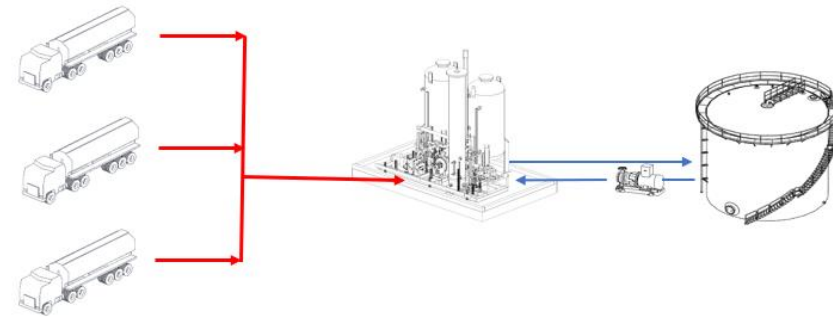

PROCESS



The GANVAC VRU is based on a well know Carbon **AD**sorption **AB**sorption **CO**ncept

- During the loading the vapours are collected from the truck and the flow is routed to one of the activated bed V21 or V22.
- The hydrocarbons are adsorbed in the activated carbon of the filters V21 or V22.
- After saturation of one of the activated bed (V21, V22), the flow is redirect to the clean filter, and the first filter is regenerated by means of vacuum.
- The vacuum system includes one rotary vane pumps
- The high concentrated vapours coming from the vacuum system are flowing trough the two absorption column of the vessel V51. In the columns the vapours are sprayed with the absorbent from the tank V51 and the hydrocarbons are recovered in the liquid
- The remaining vapours are flowing back to the inlet of the Ganvac
- To allow proper operation of the unit, the absorbent in V51 must be renewed regularly. For this V51 is connected to one of the loading product line from the gantry. When this product is loaded the absorbent is renewed by the product from the loading line and the old absorbent is re-injected into the line via the P61 pump.

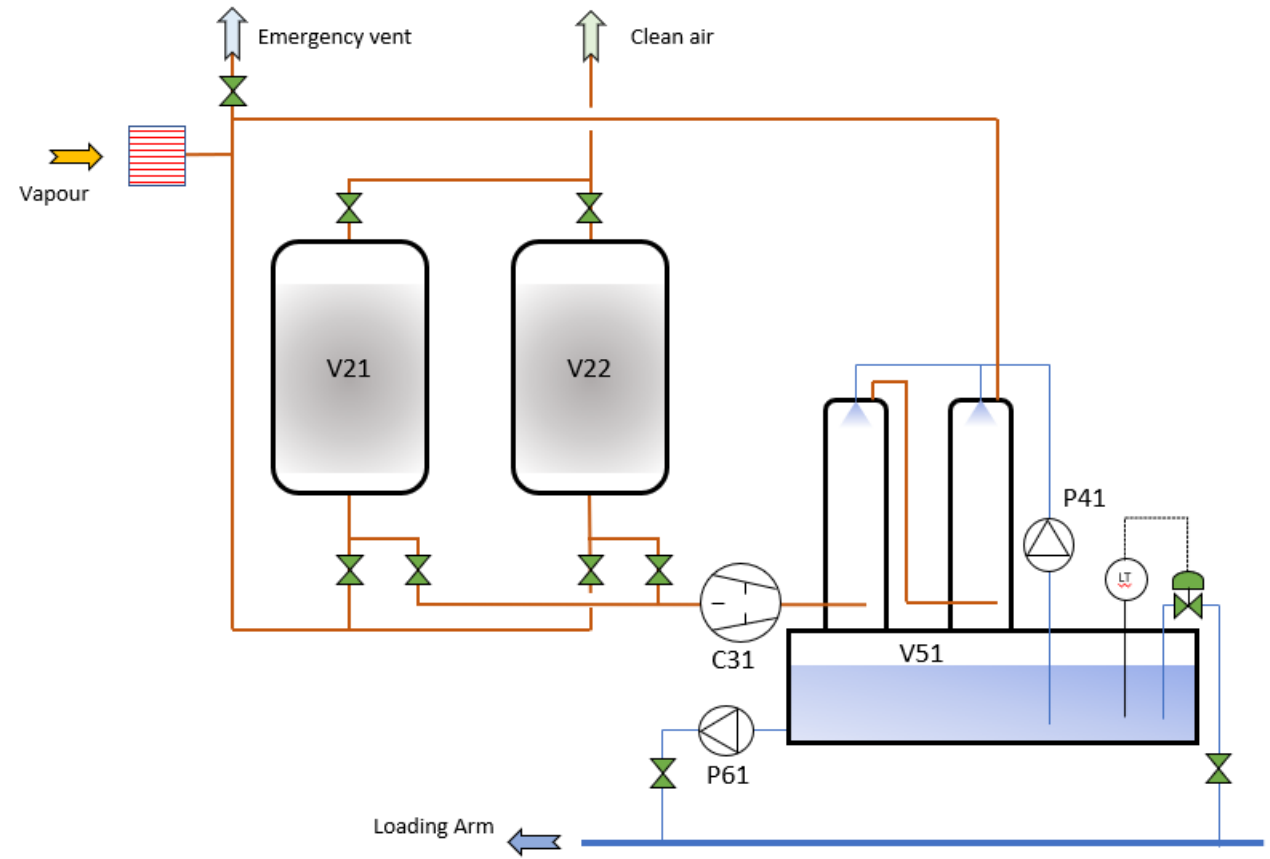

PROCESS

Step by step description

Stand By

- The unit is in stand by position with V21 on line ready to treat some vapours

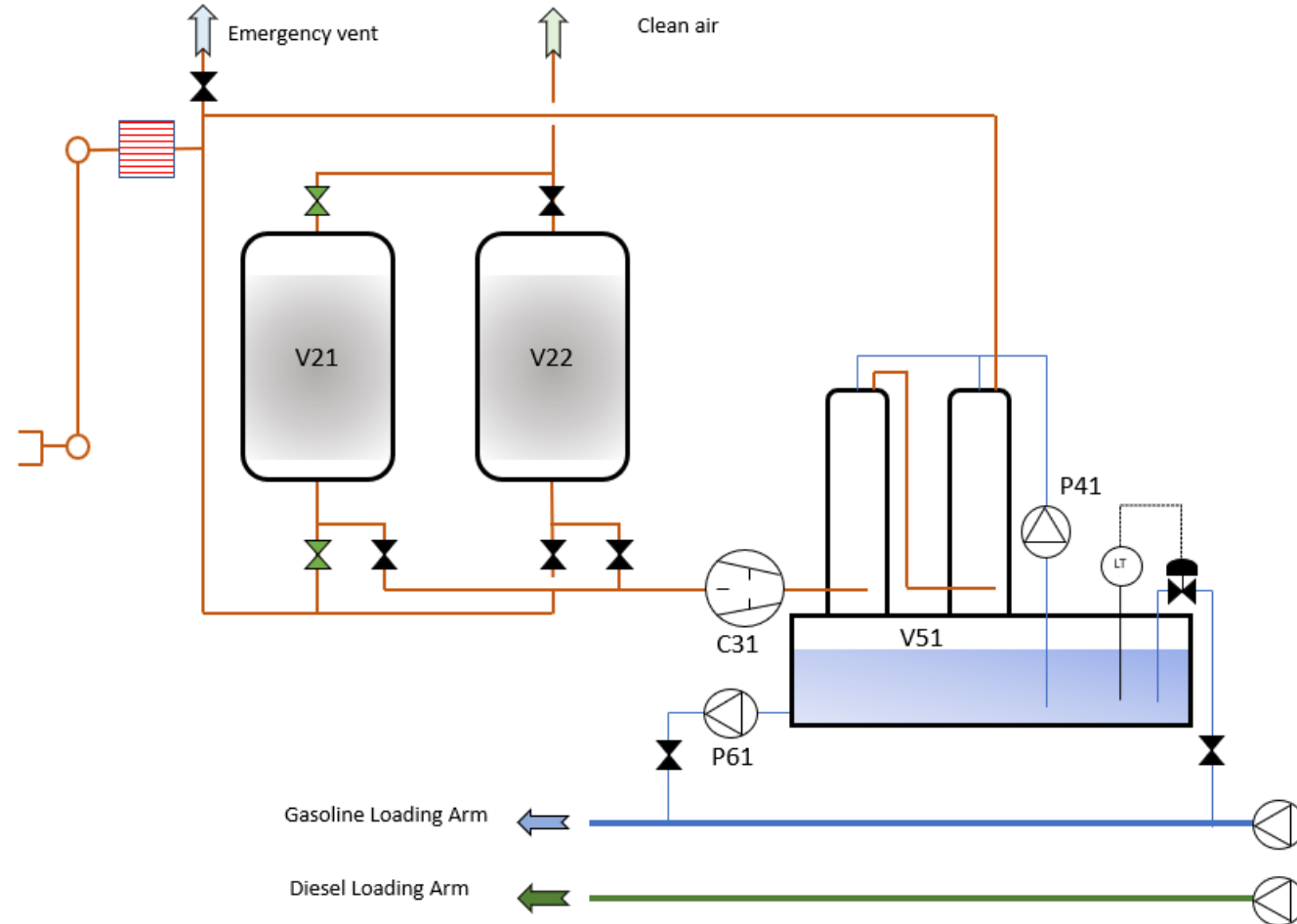

PROCESS

Step by step description

First loading « multi product »

- The truck is connected to the GANVAC to treat the vapours during the loading
- The hydrocarbons are fixed on V21 and the clean air is escaping at the vent
- The absorbent circulation is active to refresh the absorbent in V51

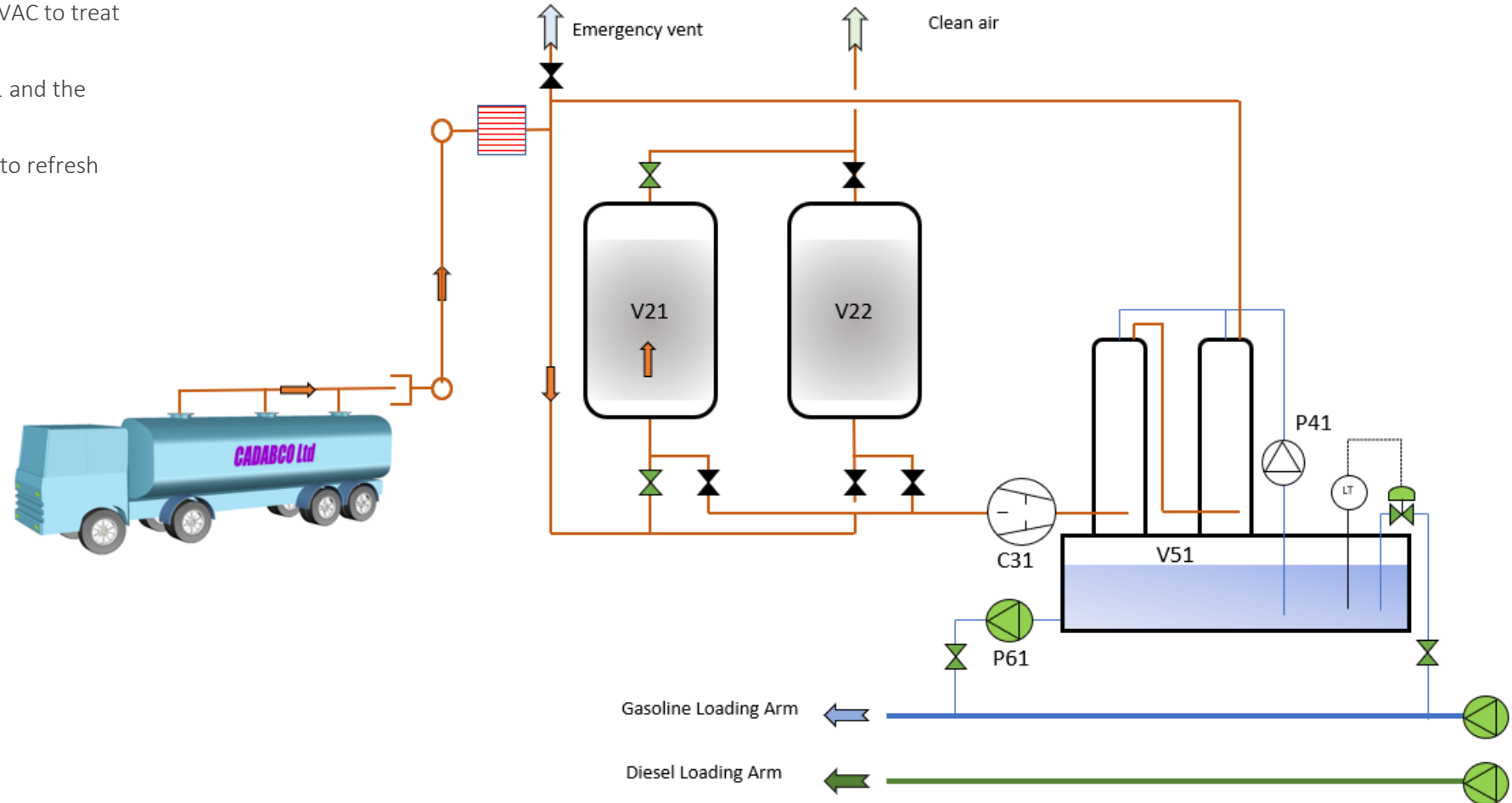

PROCESS

Step by step description

End of loading start of Regeneration

- When the truck is leaving the gantry the vessels V21 and V22 are switching
- The regeneration of V21 start by means of vacuum (C31) and re-absorption in the absorbent supplied by P41
- The unit can immediately receive vapours from the next truck (V22 and V23 on line)

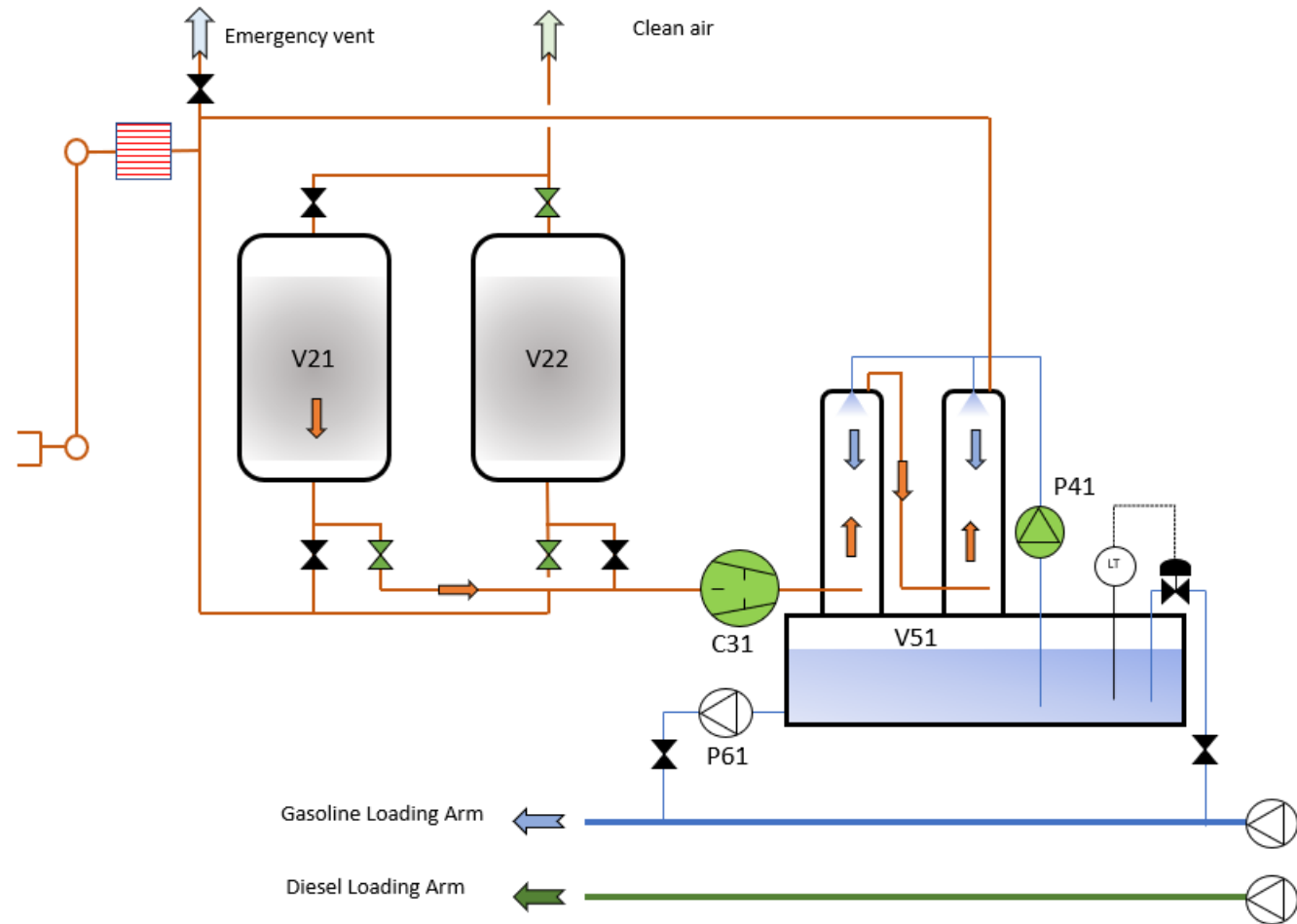

PROCESS

Step by step description

Next loading « multi product »

- The vapours are flowing through V22
- The regeneration of V21 will continue until end of the regeneration cycle
- The absorbent is refreshed during the loading time

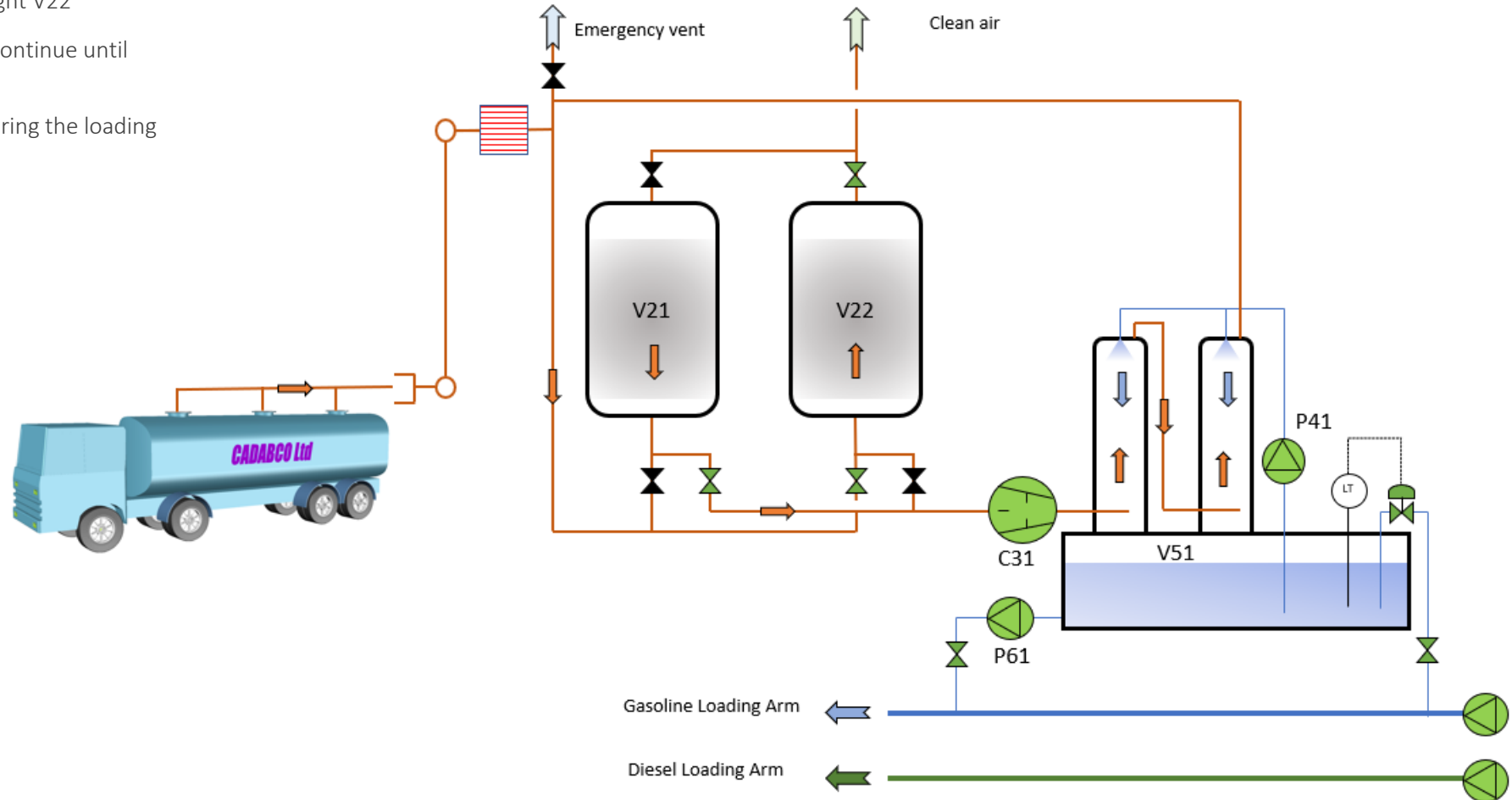

PROCESS

Step by step description

Next loading « without absorbent loading »

- The vapours are flowing through V22
- The regeneration of V21 will continue until end of the regeneration cycle
- The absorbent cannot be refreshed during the loading time. The system works with the buffer capacity of V51

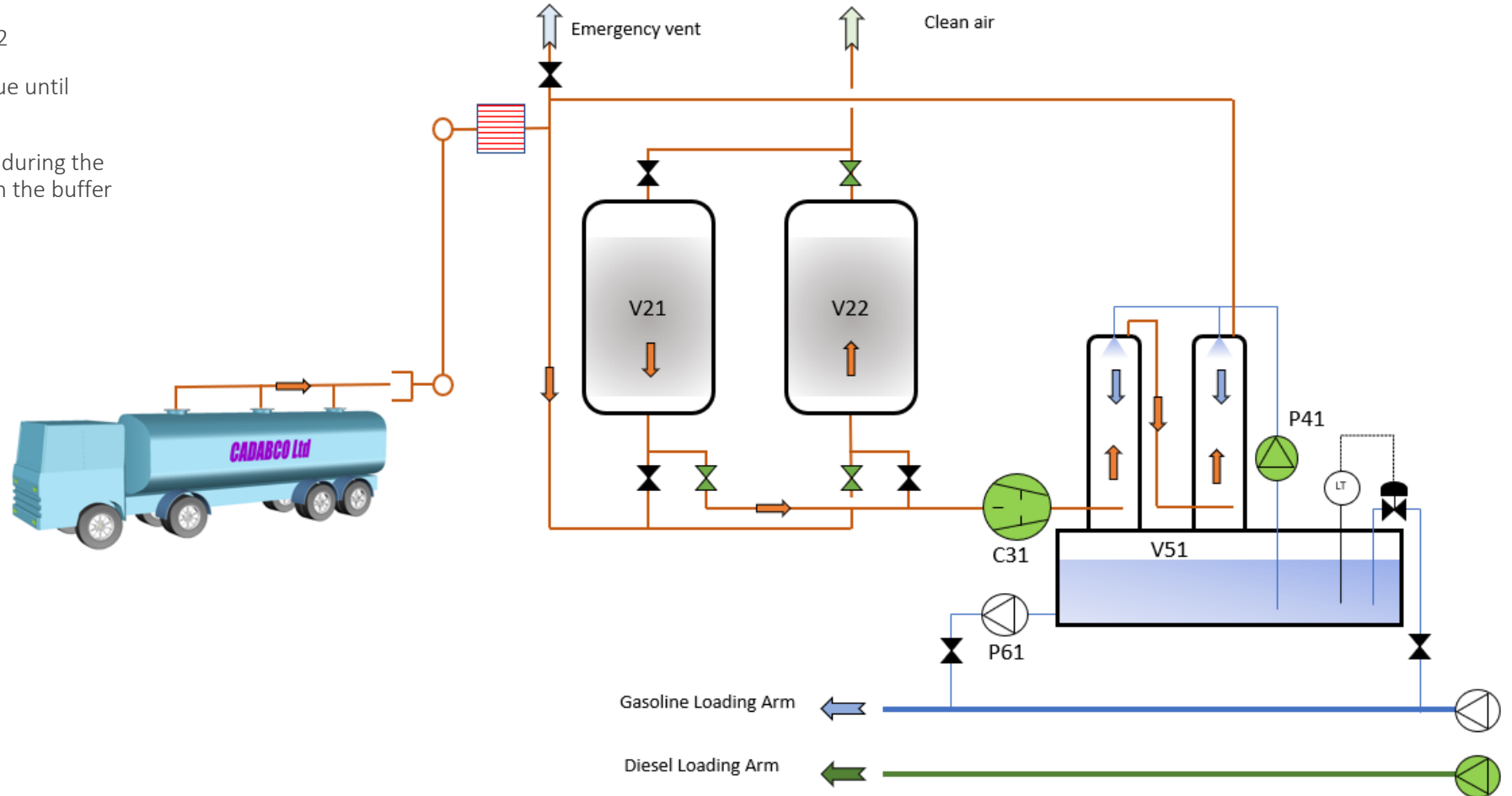

CONTROL SYSTEM

The GANVAC is controlled by a PLC installed at the skid

All the GANVAC's are connected to a central SCADA system

with several screens for process, alarms and trends

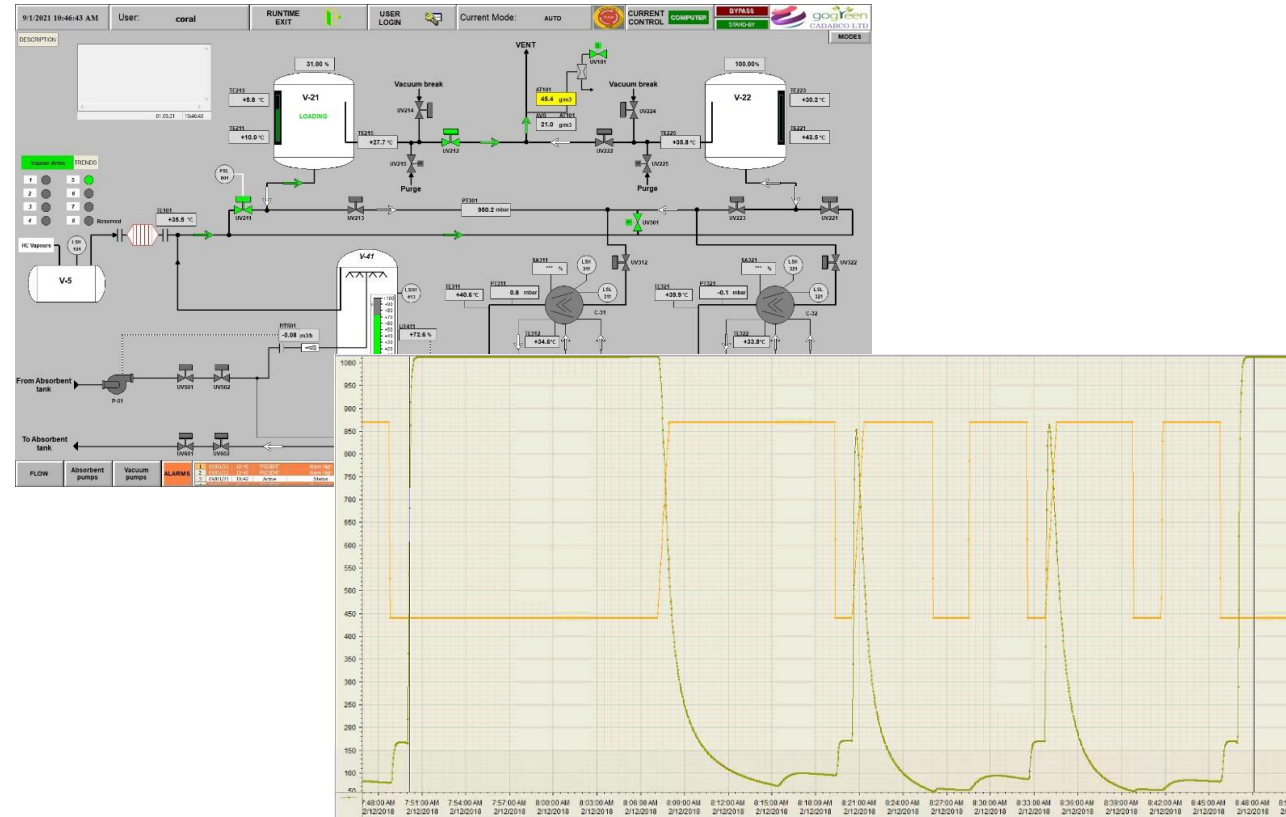

GENERAL ARRANGEMENT



- Version L : 1,2m x 5m
- Version C : 2m x 2,9m



Version L



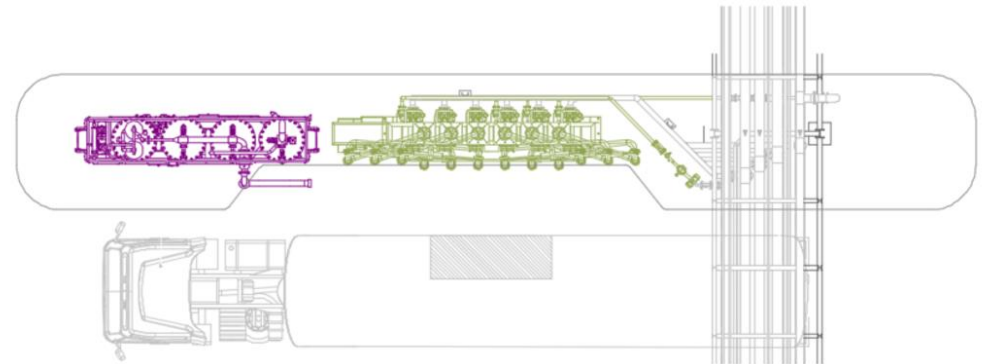
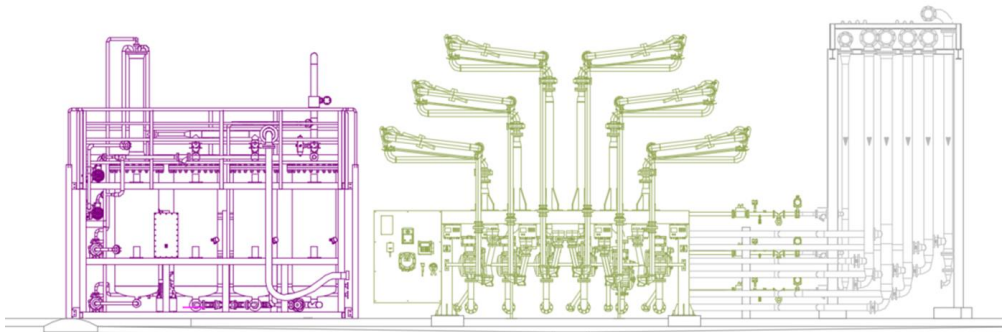

Version C





Thank you for your attention.

-  Francis Walter
-  +33 674 308 426
-  f.walter@cadabco.com
-  www.cadabco.com